



Model: RCAF-LMF-V

INSTALLATION AND OPERATING INSTRUCTIONS

SINGLE-FUNCTION WIRELESS REMOTE CONTROL SYSTEM FOR OPERATING VALVES WITH HI/LO DC MOTOR DRIVE

**IF YOU CANNOT READ OR UNDERSTAND THESE INSTALLATION INSTRUCTIONS DO NOT
ATTEMPT TO INSTALL OR OPERATE**

INTRODUCTION

This remote control system was developed to provide a safe, reliable, and user-friendly remote control system for the AFLMF valve kit. The system is operated manually from the transmitter. The system operates on radio frequencies (RF) within a 20-foot range using non-directional signals. The system operates on one of 255 security codes that are programmed into the transmitter at the factory; the remote receiver must learn the transmitter code prior to initial use.

TRANSMITTER

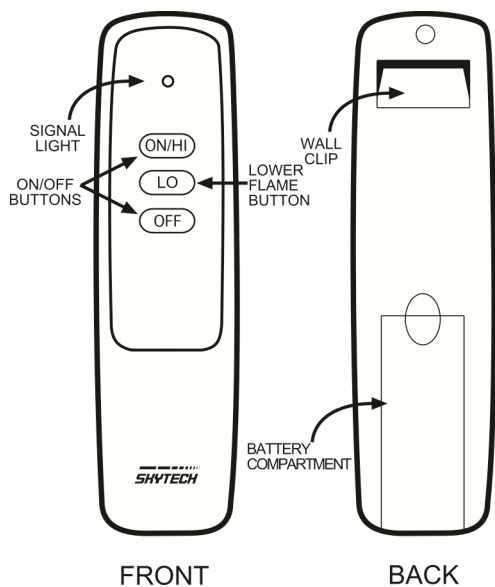

This remote control SYSTEM offers the user a battery-operated remote control to power an ON/OFF latching solenoid such as the one used with the AFLMF valve kit.

The circuit uses the battery power from the receiver to operate a HI/LO DC motor drive. The circuit has reversing polarity software that reverses the positive (+) and negative (-) output of the receiver's battery power to operate the DC motor drive (ON/HI-LO-OFF FLAME). The SYSTEM is controlled by the remote transmitter.

The transmitter operates on a 12V battery made specifically for remote controls and electronic lighters. Before using the transmitter install the 12 volt (A-23) battery in the battery compartment.

It is recommended that ALKALINE batteries always be used for longer battery life and maximum operational performance.

The transmitter has ON/HI, LO and OFF functions that are activated by pressing the button on the face of the transmitter. When a button on the transmitter is pressed, a signal light on the transmitter illuminates to verify that a signal is being sent. Upon initial use, there may be a delay of three seconds before the remote receiver will respond to the transmitter. This is part of the system's design. If the signal light does not illuminate, check the position of the transmitter's battery.

INSTALLING THE HI/LO DC MOTOR DRIVE

NOTE: The AFLMF valve kit comes with a brass cap fitting that must be removed before the HI/LO DC motor drive can be installed. Under this brass cap fitting there is a unique safety seal that prevents gas leakage after the brass cap fitting has been removed. This allows the brass cap fitting to be removed and the HI/LO DC motor drive to be installed with out shutting off the main gas valve that supplies gas to the AFLMF valve kit.

1. Remove the (2) screws from the front metal faceplate then remove the faceplate on the AFLMF valve kit and set aside.
2. Using a screwdriver remove the brass cap fitting. Note Figure 1 (Retain the brass cap fitting so if the DC motor drive is removed the brass cap fitting can be reinstalled)
3. Install the HI/LO DC motor drive into the threaded hole on the AFLMF that the brass cap fitting was removed from and screw into place and do not over tighten. **NOTE:** Figure 2

4. Replace the AFLMF front original faceplate that came installed on the AFLMF with the new faceplate supplied with the RCAF-LMF-V and reinstall the (2) screws and tighten. **Note: the new faceplate has (2) large holes.**
5. Make sure to locate the RED & BLACK wires so they come out the back of the AFLMF to connect to the receiver.

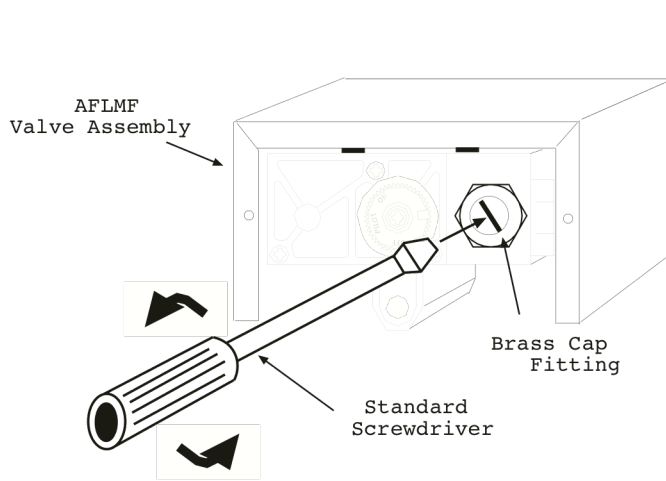

Figure #1

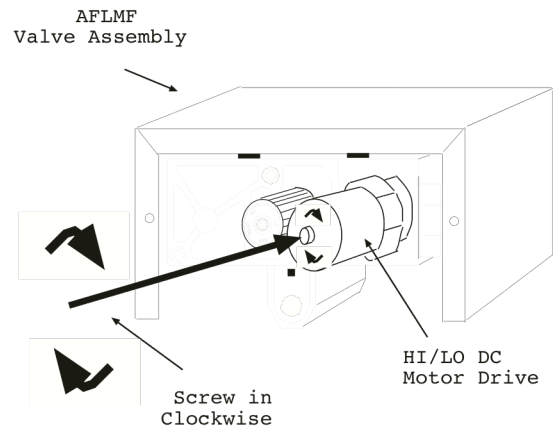

Figure #2

WIRING INSTRUCTIONS

CONNECTING THE RECEIVER TO THE AFLMF VALVE KIT WITH THE HI/LO DC MOTOR DRIVE

1. Connect the BLACK 18 gauge stranded wire with the 1/4" female terminal from the receiver to the BLACK wire with the 1/4" male terminals from the HI/LO Dc motor drive.
2. Connect the RED 18 gauge stranded wire with the 1/4" female terminal from the receiver to the RED wire with the 1/4" male terminals from the HI/LO Dc motor drive
3. After receiver wires are connected to the valve solenoid wire make sure the receiver shield is located over the receiver and then locate the receiver in an area that will not exceed the 130° F. This location will always be away from the AFLMF towards the front of the firebox.

IMPORTANT NOTE: Operation of these controls is dependent on which wire is attached to which terminal. If operation of control does not correspond to operating buttons on transmitter, reverse wire installation at the receiver or at the control.

NOTE: Up to 6.3 VDC of power is provided at the receiver terminal.

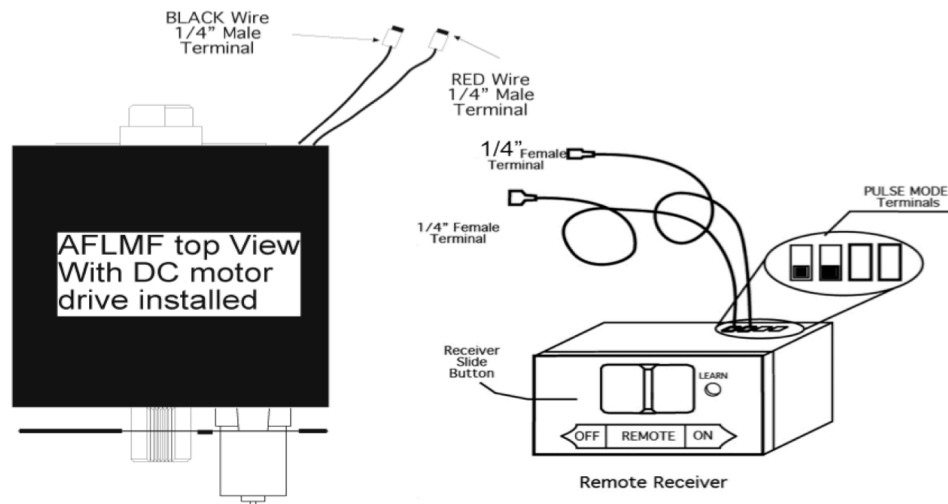

POWER SETTING – RCAF-LMF-V

The RECEIVER comes from the factory programmed to provide continuous DC voltage (5.5) VDC to 6.3 VDC) to the HI/LO DC motor drive.

REMOTE RECEIVER

IMPORTANT

THE REMOTE RECEIVER SHOULD BE POSITIONED WHERE AMBIENT TEMPERATURES DO NOT EXCEED 130° F.

The remote receiver (right) operates on four 1.5V AA-size batteries. It is recommended that ALKALINE batteries be used for longer battery life and maximum microprocessor performance. **IMPORTANT:** New or fully charged batteries are essential to proper operation of the remote receiver as a latching solenoid power consumption is substantially higher than standard remote control systems.

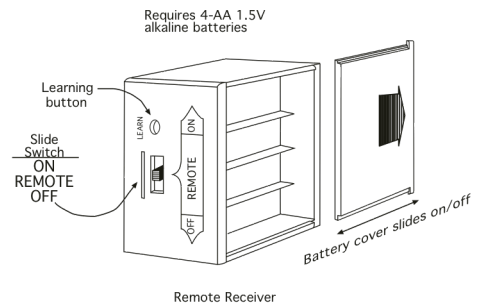

NOTE: The remote receiver will only respond to the transmitter when the 2-position slide button on the remote receiver is in the REMOTE position. The remote receiver houses the microprocessor that responds to commands from the transmitter to control system operation.

FUNCTIONS:

1. **With the slide switch in the REMOTE position, the system will only operate if the remote receiver receives commands from the transmitter.** Upon initial use or after an extended period of no use, the ON/HI button may have to be pressed for up to three seconds to activate the motor drive. If the system does not respond to the transmitter on initial use, see LEARNING TRANSMITTER TO RECEIVER section.
2. With the slide in the **OFF** position, the system is **OFF**.
3. With the slide switch in the **ON** position (toward the LEARN button), the receiver will manually send power for five seconds to open the motor drive. It will remain **ON** until the slide switch is placed in the **OFF** or **REMOTE** position.
4. It is suggested that the slide switch be placed in the **OFF** position if you will be away from your home for an extended period of time. Placing the slide switch in the **OFF** position also functions as a safety "lock out" by both turning the system **OFF** and rendering the transmitter inoperative.

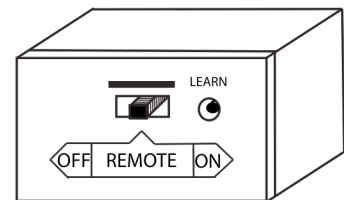

INSTALLATION INSTRUCTIONS

WARNING

DO NOT CONNECT REMOTE RECEIVER DIRECTLY TO 110-120VAC POWER. THIS WILL BURN OUT THE RECEIVER. FOLLOW INSTRUCTIONS FROM MANUFACTURER OF GAS VALVE FOR CORRECT WIRING PROCEDURES. IMPROPER INSTALLATION OF ELECTRIC COMPONENTS CAN CAUSE DAMAGE TO GAS VALVE AND REMOTE RECEIVER.

INSTALLATION

The remote receiver can be mounted on or near the fireplace hearth. **PROTECTION FROM EXTREME HEAT IS VERY IMPORTANT.** Like any piece of electronic equipment, the remote receiver should be kept away from temperatures exceeding 130° F inside the receiver case. Battery life is also significantly shortened if batteries are exposed to high temperatures.

Make sure the remote receiver switch is in the OFF position. For best results it is recommended that 18 gauge stranded wires should be used to make connections and no longer than 20-feet.

GENERAL INFORMATION

LEARNING TRANSMITTER TO RECEIVER

Each transmitter uses a unique security code. It will be necessary to press the LEARN button on the receiver to accept the transmitter security code upon initial use, if batteries are replaced, or if a replacement transmitter is purchased from your dealer or the factory. In order for the receiver to accept the transmitter security code, be sure the slide button on the receiver is in the REMOTE position; the receiver will **not** LEARN if the slide switch is in the ON or OFF position. The LEARN button is located on the front face of the receiver; inside the small hole labeled LEARN. Using a small screwdriver or end of a paperclip gently press and release the black LEARN button inside the hole. When you release the LEARN button the receiver will emit an audible "beep". After the receiver emits the beep press the transmitter ON/HI button and release. The receiver will emit several beeps indicating that the transmitter's code has been accepted into the receiver.

The microprocessor that controls the security code matching procedure is controlled by a timing function. If you are unsuccessful in matching the security code on the first attempt, wait 1 - 2 minutes before trying again--this delay allows the microprocessor to reset its timer circuitry--and try up to two or three more times.

TRANSMITTER WALL CLIP

The transmitter can be hung on a wall using the clip provided. If the clip is installed on a solid wood wall, drill 1/8" pilot holes and install with the screws provided. If it is installed on a plaster/wallboard wall, first drill two 1/4" holes into the wall. Then use a hammer to tap in the two plastic wall anchors flush with the wall; then install the screws provided.

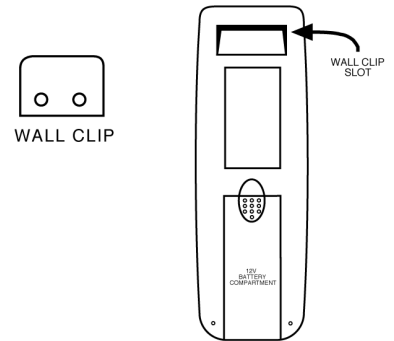

OPERATION

4. This remote control will operate the gas valve DC motor drive ON/HI to open the gas flow to full ON.
5. When the ON/HI button is depressed the transmitter sends a RF signal to the receiver. The receiver then will send 5 seconds of continuous 6 volts of power to the DC motor drive. The DC motor drive then opens the gas flow to the burner then to full ON.
6. When the LO button is pressed the receiver will send a continuous 6 volts of power to the DC motor drive for as long as the button is pressed to lower the main burner flame.
7. When the OFF button is depressed the transmitter sends a RF signal to the receiver. The receiver then will send 5 seconds of continuous 6 volts of power to the DC motor drive. The DC motor drive then closes the gas flow to the burner then to full OFF.
8. The remote control will only work with the hand held transmitter. The receiver slide switch is only for positive OFF or REMOTE operation.

NOTE: Extensive use of the HI/LO DC motor drive will reduce the receiver's battery life significantly.

BATTERY LIFE

Life expectancy of the alkaline batteries in the RCAF-LMF-V can be up to 12 months depending on use of the solenoid function. Replace all batteries annually. When the transmitter no longer operates the remote receiver from a distance it did previously (i.e., the transmitter's range has decreased) or the remote receiver does not function at all, the batteries should be checked. It is important that the remote receiver batteries are fully charged, providing combined output voltage of at least 5.0 volts. The transmitter should operate with as little as 9.0 volts battery power. NOTE: Extensive use of the Solenoid will reduce the receiver's battery life significantly.

TROUBLE SHOOTING

If you encounter problems with your fireplace system, the problem may be with the fireplace itself or it could be with the RCAF-LMF-V remote system. Review the fireplace manufacturer's operation manual to make sure all connections are properly made. Then check the operation of the remote in the following manner:

1. Make sure the batteries are correctly installed in the RECEIVER. One reversed battery will keep receiver from operating properly.
2. Check battery in TRANSMITTER to ensure contacts are touching (+) and (-) ends of battery. Bend metal contacts in for tighter fit.
3. Be sure RECEIVER and TRANSMITTER is within 20 to 25-foot operating range.
4. Keep RECEIVER from temperatures exceeding 120° F. Battery life shortened when ambient temperatures are above 115° F.
5. If RECEIVER is installed in tightly enclosed metal surround, the operating distance will be shortened.

SPECIFICATIONS

BATTERIES: Transmitter 12V - (A23)
Remote Receiver 6V - 4 ea. AA 1.5 Alkaline FCC ID No.'s: transmitter - K9L1002TX; receiver - K9L300IRX
Operating Frequency: 303.8 MHZ Canadian ISC ID No.'s: transmitter - 2439 102 728; receiver - 2439 102 728A

FCC REQUIREMENTS

NOTE: THE MANUFACTURER IS NOT RESPONSIBLE FOR ANY RADIO OR TV INTERFERENCE CAUSED BY UNAUTHORIZED MODIFICATIONS TO THIS EQUIPMENT. SUCH MODIFICATIONS COULD VOID THE USER'S AUTHORITY TO OPERATE THE EQUIPMENT.

FOR TECHNICAL SERVICE, CALL:

U. S. INQUIRIES

(888) 672-8929 or (260) 459-1703

CANADIAN INQUIRIES

(877) 472-3923

WEBSITE: skytechpg.com

MANUFACTURED EXCLUSIVELY FOR SKYTECH II, INC.